

Differential Motions and Velocities

Jacobian matrix

- Multi input & multi output system
 - System Model

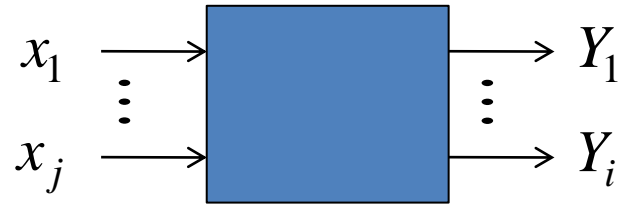

$$Y_1 = f_1(x_1, \dots, x_j)$$

$$\vdots$$

$$Y_i = f_i(x_1, \dots, x_j)$$

Jacobian Matrix

- Differential System
 - Chain rule

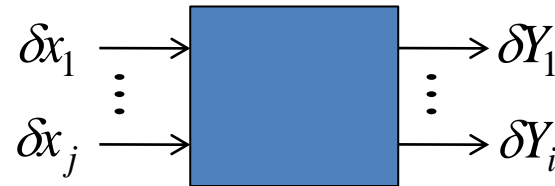

$$\delta Y_1 = \frac{\partial f_1}{\partial x_1} \delta x_1 + \cdots + \frac{\partial f_1}{\partial x_j} \delta x_j$$

\vdots

$$\delta Y_i = \frac{\partial f_i}{\partial x_1} \delta x_1 + \cdots + \frac{\partial f_i}{\partial x_j} \delta x_j$$

- Matrix Form

$$\begin{bmatrix} \delta Y_1 \\ \vdots \\ \delta Y_i \end{bmatrix} = \begin{bmatrix} \frac{\partial f_1}{\partial x_1} & \cdots & \frac{\partial f_1}{\partial x_j} \\ \vdots & \vdots & \vdots \\ \frac{\partial f_i}{\partial x_1} & \cdots & \frac{\partial f_i}{\partial x_j} \end{bmatrix} \begin{bmatrix} \delta x_1 \\ \vdots \\ \delta x_j \end{bmatrix}$$

└──────────┬──────────┘ J : Jacobian matrix

Differential Motion

- Forward Kinematics

$$x = f_1(\theta_1, \theta_2, \theta_3, \theta_4, \theta_5, \theta_6)$$

$$y = f_2(\theta_1, \theta_2, \theta_3, \theta_4, \theta_5, \theta_6)$$

$$z = f_3(\theta_1, \theta_2, \theta_3, \theta_4, \theta_5, \theta_6)$$

$$\phi_x = f_4(\theta_1, \theta_2, \theta_3, \theta_4, \theta_5, \theta_6)$$

$$\phi_y = f_5(\theta_1, \theta_2, \theta_3, \theta_4, \theta_5, \theta_6)$$

$$\phi_z = f_6(\theta_1, \theta_2, \theta_3, \theta_4, \theta_5, \theta_6)$$

- Differential Motion

$$\begin{bmatrix} dx \\ dy \\ dz \\ d\phi_x \\ d\phi_y \\ d\phi_z \end{bmatrix} = \begin{bmatrix} \frac{\partial f_1}{\partial \theta_1} & \dots & \frac{\partial f_1}{\partial \theta_6} \\ \vdots & \vdots & \vdots \\ \frac{\partial f_6}{\partial \theta_1} & \dots & \frac{\partial f_6}{\partial \theta_6} \end{bmatrix} \begin{bmatrix} d\theta_1 \\ d\theta_2 \\ d\theta_3 \\ d\theta_4 \\ d\theta_5 \\ d\theta_6 \end{bmatrix} \Leftrightarrow D = J D_\theta$$

Differential Motion

- Velocities

$$\begin{bmatrix} dx / dt \\ dy / dt \\ dz / dt \\ d\phi_x / dt \\ d\phi_y / dt \\ d\phi_z / dt \end{bmatrix} = \begin{bmatrix} \frac{\partial f_1}{\partial \theta_1} & \dots & \frac{\partial f_1}{\partial \theta_6} \\ \vdots & \vdots & \vdots \\ \frac{\partial f_6}{\partial \theta_1} & \dots & \frac{\partial f_6}{\partial \theta_6} \end{bmatrix} \begin{bmatrix} d\theta_1 / dt \\ d\theta_2 / dt \\ d\theta_3 / dt \\ d\theta_4 / dt \\ d\theta_5 / dt \\ d\theta_6 / dt \end{bmatrix}$$

\Leftrightarrow

$$V = J(\Theta) \dot{\Theta}$$

\Leftrightarrow

$$\dot{\Theta} = J^{-1}(\Theta) V$$

Examples

(ex1) Type 1 robot

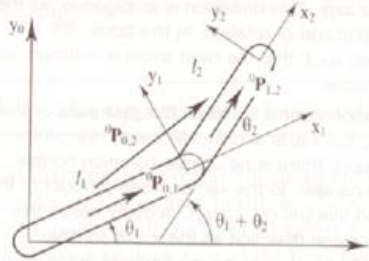

$$x = l_1 c_1 + l_2 c_{12}$$
$$y = l_1 s_1 + l_2 s_{12}$$

$$l_1 = l_2 = 1(m), \quad \theta_1 = \frac{\pi}{3}, \theta_2 = \frac{\pi}{6}, \dot{\theta}_1 = 2(\text{rad/s}), \dot{\theta}_2 = 4(\text{rad/s}) \Rightarrow \dot{x}, \dot{y} = ?$$

Examples

(ex1) Type 4 robot

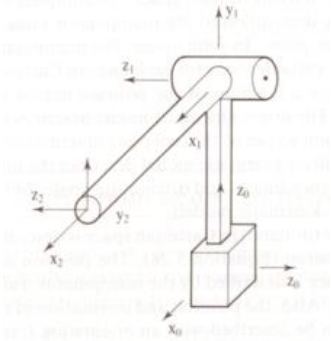

$${}^R T_H = \begin{bmatrix} c_2 & -s_2 & 0 & l_2 c_2 \\ 0 & 0 & -1 & 0 \\ s_2 & c_2 & 0 & d_1 + l_2 c_2 \\ 0 & 0 & 0 & 1 \end{bmatrix}$$

=> Jacobian matrix ?

Singularities

- Singularities (특이점)
 - Inverse Jacobian ($J^{-1}(\Theta)$) 이 존재하지 않는 joint 위치 (Θ)
 - $\Rightarrow \det(J(\Theta)) = 0$ 인 Θ
 - \Rightarrow Joint 구동 시 joint velocity $=\infty$ 인 joint 위치
 - Type
 - Workspace boundary singularities
 - Workspace interior singularities

(ex) Type 1 robot

Singularities

(ex) Type 1 robot

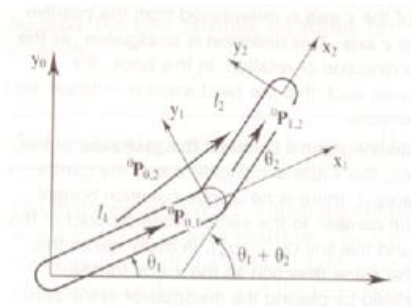

$$J = \begin{bmatrix} -l_1 s_1 - l_2 s_{12} & -l_2 s_{12} \\ l_1 c_1 + l_2 c_{12} & l_2 c_{12} \end{bmatrix}$$

Singularities

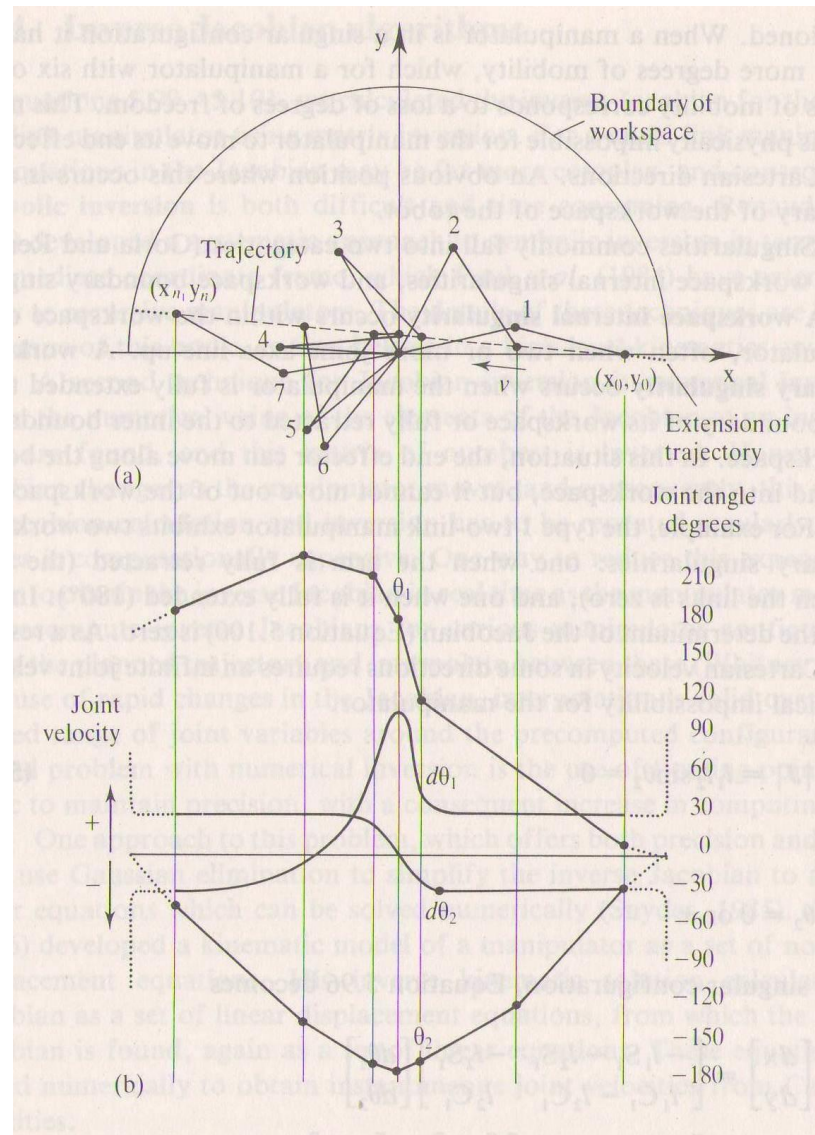

Singularities

- Singularities Avoidance
 - 특이점 회피 이동경로 계획

